

BIG BEE ROTARY CUTTER

OWNER'S MANUAL

AGRI-FORTY TWO
42"

AGRI-FOUR
48"

AGRI-FIVE
60"

AGRI-SIXTY SIX
66"

AGRI-SEVENTY TWO
72"

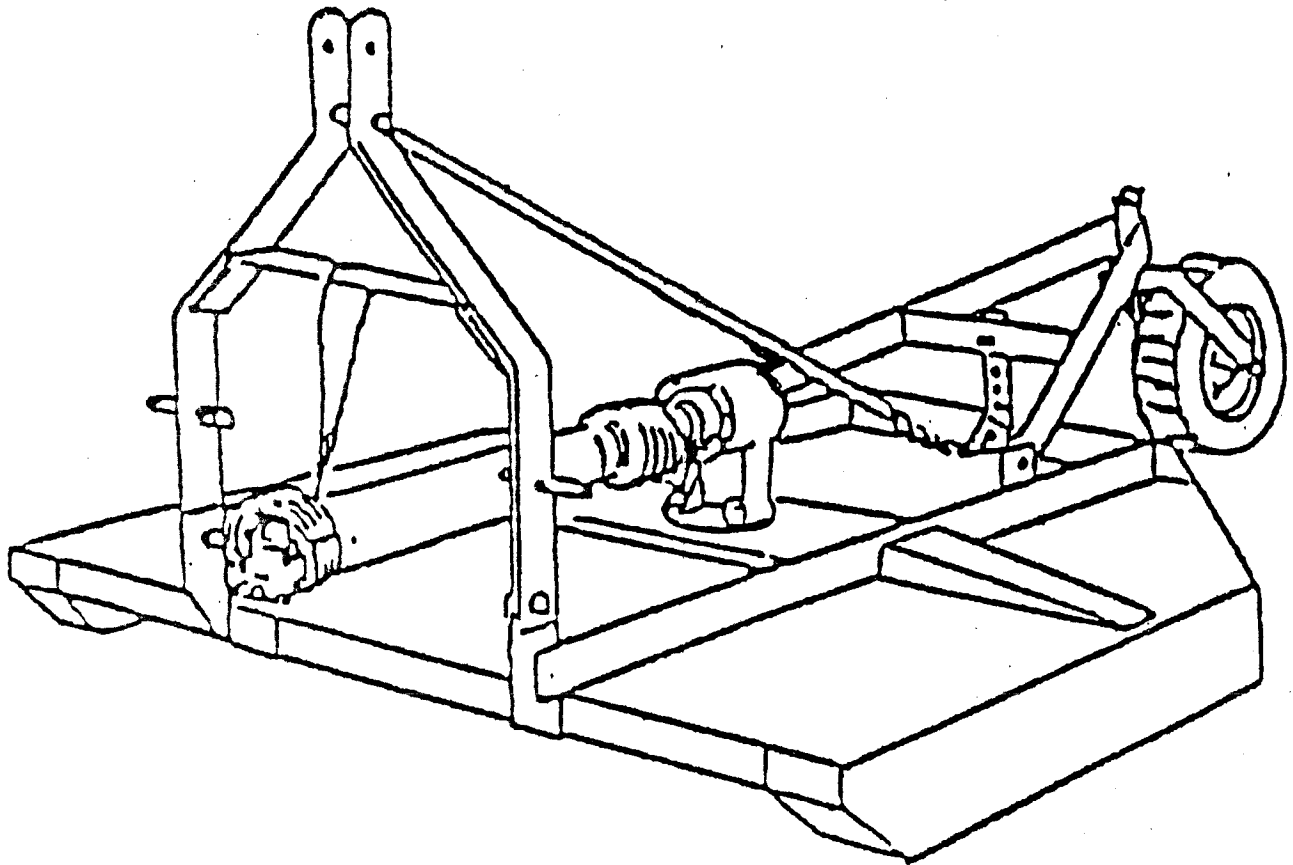

SAFETY PRECAUTIONS

Due to the type of performance for which this machine was designed, the operator should be very careful and practice all safety precautions during operation. Being of basic design throughout the farm equipment industry, rotary cutters have fast moving blades that can throw objects that the operator runs over. It is possible to do serious injury to yourself or to others, if you fail to read and practice the foregoing safety rules. **ONLY EXPERIENCED** and trained operators with a through understanding of the purpose and capabilities of this machine should operate it.

1. **IMPORTANT!** Read and become familiar with the instructions on the rotary cutter decals. These decals have been placed at various places on the machine to remind you to be cautious for your protection, as well as others.
2. Before operating the rotary cutter carefully inspect the area on which the rotary cutter will be used. Be sure to remove all objects that might be thrown by the rotating blades. Also, note any gullies, ditches, or rough terrain when you are inspecting.
3. Check the machine frequently to be sure there are no loose bolts, and that snap rings are in place.
4. Always use and maintain in place all PTO guards furnished with the rotary cutter, as well as the guards furnished with the tractor.
5. Disengage the PTO and cut off the tractor engine before leaving the tractor.
6. It is recommended that the tractor be equipped with a roll-bar, and a seat belt. This is the operator's own responsibility for his safety.
7. It is noted that on tractors with "live" PTO, the centrifugal force of the rotating blades will tend to force the tractor in the direction of travel. This can result in an accident or injury if the operator does not reduce his speed before turning or allowing adequate distance between the tractor and turning point or obstacle. (Your dealer has free-wheel and over-running couplers to curtail the centrifugal force. The couplers serve as an added safety device.)
8. The blades and PTO shaft will continue to rotate for a short time after the tractor PTO power is cut off. Be sure all rotation has completely stopped before attempting to service the machine or approach it for any reason.
9. Never position yourself under the machine for any reason. It could fall on you!!!! Never manually feed the machine for any reason. Never put your hands or feet under the deck of the cutter without first being sure that the blades have ceased all movement, and all power is cut off.
10. Chain guards (optional equipment) should be added to the machine when it is used in areas where people, animals, or property may be hit or endangered by thrown objects. The rapidly rotating blades may strike and throw wire, sticks, loose rocks, or trash with considerable force. Even with chain guards, it is recommended that the operator be sure to keep all persons and animals far enough away from the operating area to be completely clear of thrown objects.
11. Never allow riders on machine or tractor!
12. Transport machine at a safe speed.

OPERATION

THE BIG BEE ROTARY CUTTER IS DESIGNED TO BE USED WITH TRACTORS FROM 15 HP TO 70 HP WITH RPM PTO.

1. Check gear box for lubricant.
2. Check all lubrication points on PTO shaft and tail wheel.
3. Be sure all bolts are tight and snap rings are in place.
4. Be sure the rotary cutter is properly mounted on the tractor.
5. Adjust and level rotary cutter for desired cutting height.

ADJUSTING LEVEL OF CUTTER ON YOUR TRACTOR

CUTTER TOO LOW IN FRONT

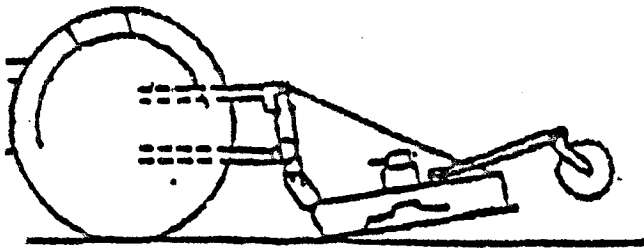

INCORRECT

The above position makes the blade too high causing skipping and uneven cutting. It also allows the blades to strike the ground causing the slip clutch to slip excessively and the blades to become worn.

CUTTER TOO LOW IN REAR

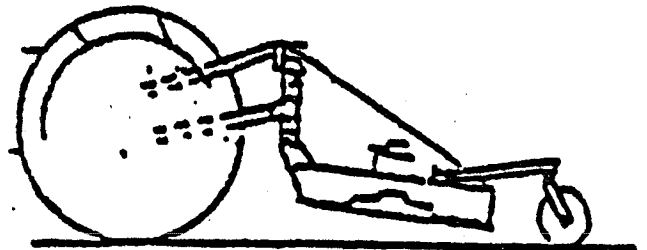

INCORRECT

The above position causes excessive wear and tear on the tail wheel. The rear skirt drags allowing un-necessary debris to be collected under the Rotary Cutter.

Cutter Level

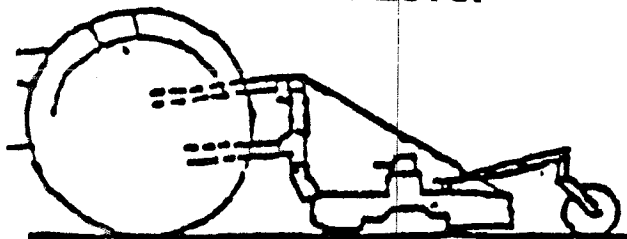

CORRECT

STARTING FOR THE FIRST TIME

1. If everything is in place, and the rotary cutter is properly connected to the tractor, **start the tractor and raise the rotary cutter slowly. While watching the PTO shaft, raise and lower the rotary cutter until you have positioned the PTO shaft to the shortest telescoping point. This position will check the PTO shaft to make sure it is not too long. With the shaft positioned at it's shortest length the two telescoping shaft should lack two inches (2") meeting. Now, check the PTO shaft to be sure it is not too short. *** Position the rotary cutter so that the PTO shaft will be at it's longest position. At this position the two telescoping shafts should engage at least six inches (6"). Be sure the PTO clears the front of the cutter deck when cutter is raised. If it does not clear, readjust the top link on your tractor, to correct this problem. You may want to set the stop on your hydraulic control level, so that the cutter will not accidentally be raised too high. Now, engage the PTO, slowly, let the rotary cutter run slowly for several seconds and gradually increase throttle to operating speed. Watch carefully for signs of excessive vibration or unusual noises. If any are noticed, disengage PTO, cut off tractor immediately, wait for complete stop of all moving parts, and investigate cause. A new gearbox may be noisy at first, but usually a few hours use will mesh the gears and create a quieter, smoother operation.**
2. **We suggest that you get the feel of your rotary cutter on open familiar ground. Remember that the centrifugal force of the rotary blades and carrier can keep pushing you forward even after you have disengaged your clutch, unless your tractor is equipped with live PTO or an over-runner. Therefore, approach obstacles with caution.**

*****If it is determined that the PTO shaft is either long or too short for your tractor, see your dealer for correct shaft lengths. This is not a frequent problem, however, the correct shaft length should be checked to avoid damage to the PTO shaft or other components.**

ASSEMBLY AND SET – UP INSTRUCTIONS

- A. Set up A-frame and position hitch pins into proper position. Be sure to use lock washers and tighten bolts securely. Attach flex chain brace to A-frame then fasten chain end on tail wheel adjustment bracket.**
- B. Remove the snap ring from in-put shaft on gear box, attach the PTO shaft and install shear bolt. Be sure to replace the snap rings to gearbox in-out shaft. The snap ring will hold the PTO shaft in place if the shear bolt is sheared.**
- C. Check all bolts including gear box mounting bolts, blade bolts, and blade carrier bolts.**
- D. Adjust the tail wheel bracket to level the rotary cutter or obtain desired cutting position.**
- E. Lubricate gearbox, tail wheel hub, tail wheel hub, tail wheel spindle, PTO U-joints.**
- F. Attach rotary cutter to the tractor.**

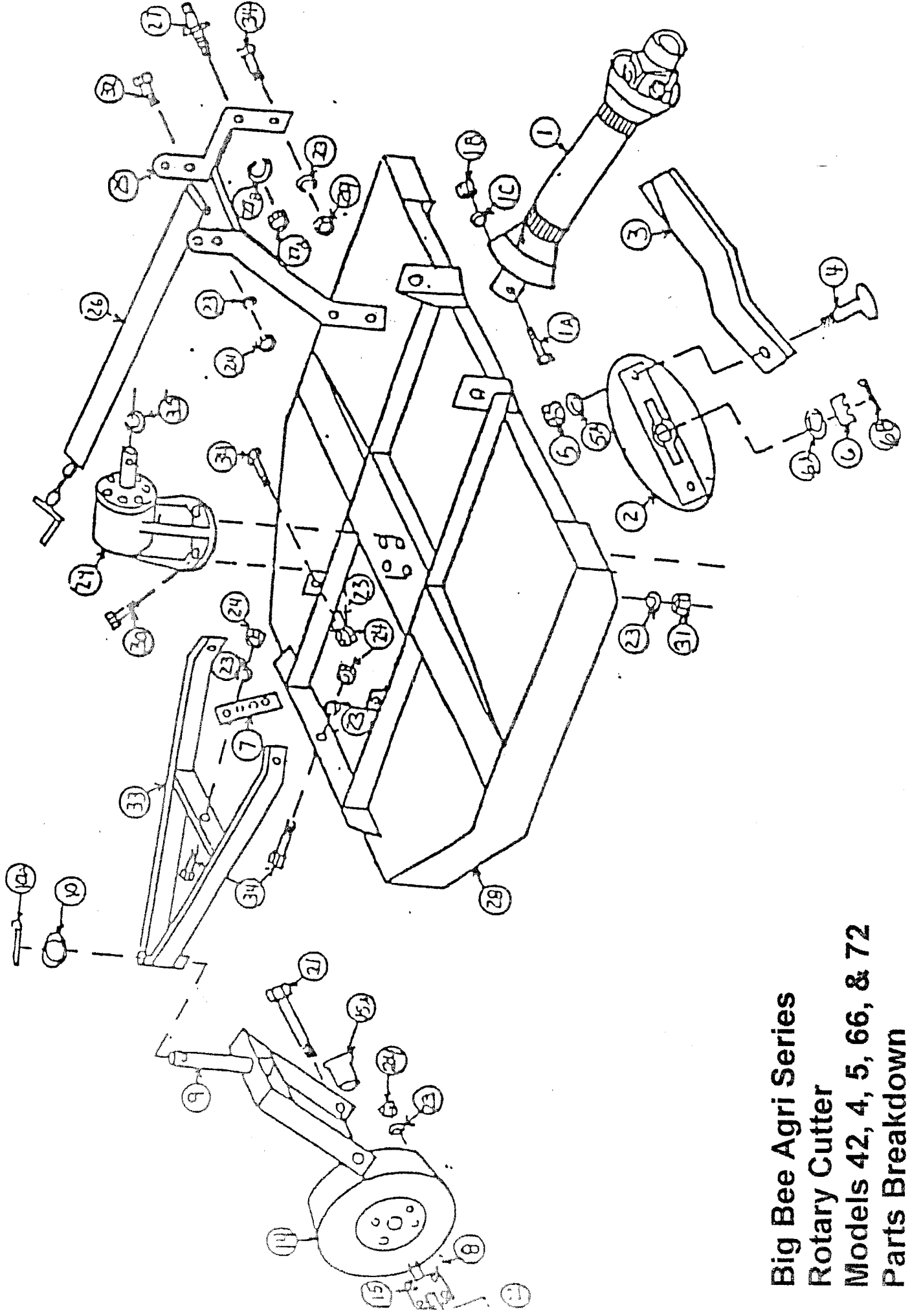

**Big Bee Agri Series
 Rotary Cutter
 Models 42, 4, 5, 66, & 72
 Parts Breakdown**

Number	Part #	Description	Quantity
1	899	PTO shaft – Agri 38	1
1	801	PTO shaft – Agri 42	1
1	805M10130	PTO shaft – Agri 4	1
1	807 7453	PTO shaft – Agri 5	1
1	807	PTO shaft – Agri 66	1
1	807-72	PTO shaft – Agri 72	1
1A	HW8077	½" x 3" Grade 2 shear bolt	1
1B	HW1003	Shear bolt nut ½" US	1
1C	HW1002	Shear bolt washer ½" lock	1
2	621	Blade carrier – Complete (Sold as one part / nut can be bought separately)	1
2	624	Round disc	1
2	623	Bar	1
2	622	Hub 12 spline	1
3	628	Blade – Agri 42	2
3	629	Blade – Agri 4	2
3	630	Blade – Agri 5	2
3	635	Blade – Agri 66	2
3	635-72	Blade – Agri 72	2
4	632	Blade bolt	2
5	633	Blade bolt nut 1 1/8" 12 SAE	2
5A	HW633A	Blade bolt lock washer 1 1/8"	2
6	634	Nut, Bottom shaft (stump jumper)	1
6A	HW634A	Washer, bottom shaft	1
6B	HW634B	Cotter key, bottom shaft	1
7	643	Bracket adjuster, tail wheel	1
8	HW1012	Grease fittings	2
9	645	Fork, tail wheel (ALL)	1
10	647	Washer, fork, tail wheel (ALL)	1
10A	HW648	Cotter key, fork, tail wheel (ALL)	1
14	655	Tire and rim, tail, wheel	1
15	656	Hub, tail wheel (Complete with bushings)	1
15A	655A	Hub, tail wheel bushings	2
21	663	Axle, tail wheel	1
21A	633A	Washer, tail wheel	1
21B	633B	Nut, tail wheel	1
22	HW1056	5/8" x NC X 1" hex bolt	4
23	HW1057	5/8" Lock washer	11
24	HW1058	5/8" x NC Hex nut	11
25	670	A-frame, 2 piece assy for Agri 42	1
25	677	A-frame, welded assy (Agri 4,5, & 66)	1
26	6770	Chain bracket for Agri 42	2
26	6780	Chain brace for Agri 4	1
26	6790	Chain brace for Agri 5	1
26	6791	Chain brace for Agri 66	1
26	6791-72	Chain brace for Agri 72	1
27	HW1007	7/8" Draw pin	2
27A	HW1009	7/8" NF Hex nut	2
27B	HW1008	7/8" Lock washer	2
28	6860P	Deck (Main Body) Agri 42	1
28	6870P	Deck (Main Body) Agri 4	1
28	6880P	Deck (Main Body) Agri 5	1
28	6881P	Deck (Main Body) Agri 66	1
28	6881-72	Deck (Main Body) Agri 72	1
29	6882	Gearbox	1
30	HW6882A	5/8" x 2" Grade 5 SAE Hex bolt	4
31	HW6882B	5/8" SAE Hex nut	4
32	HW6884	5/8" x NC x 4 ½" Grade 2 Hex bolt	1

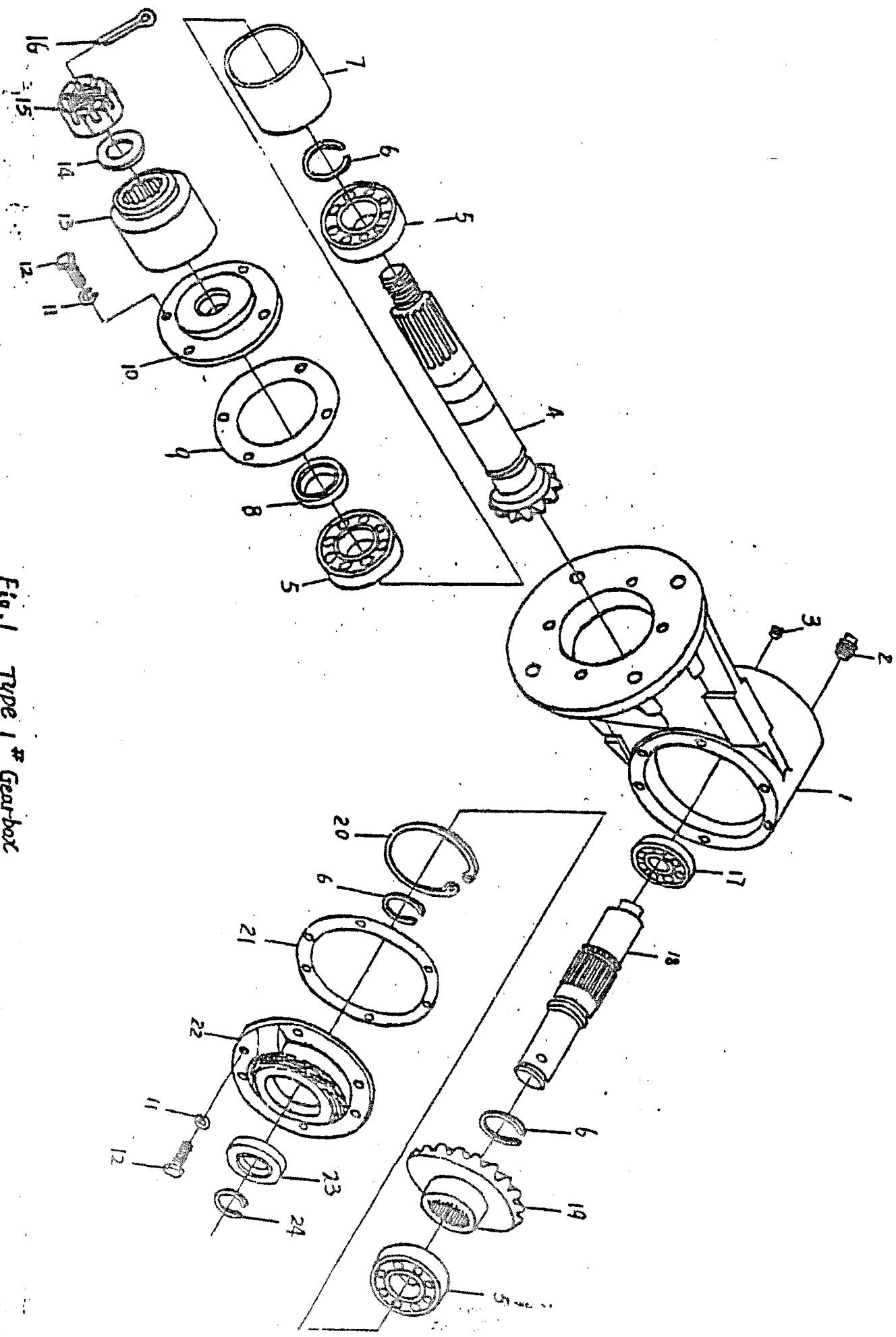
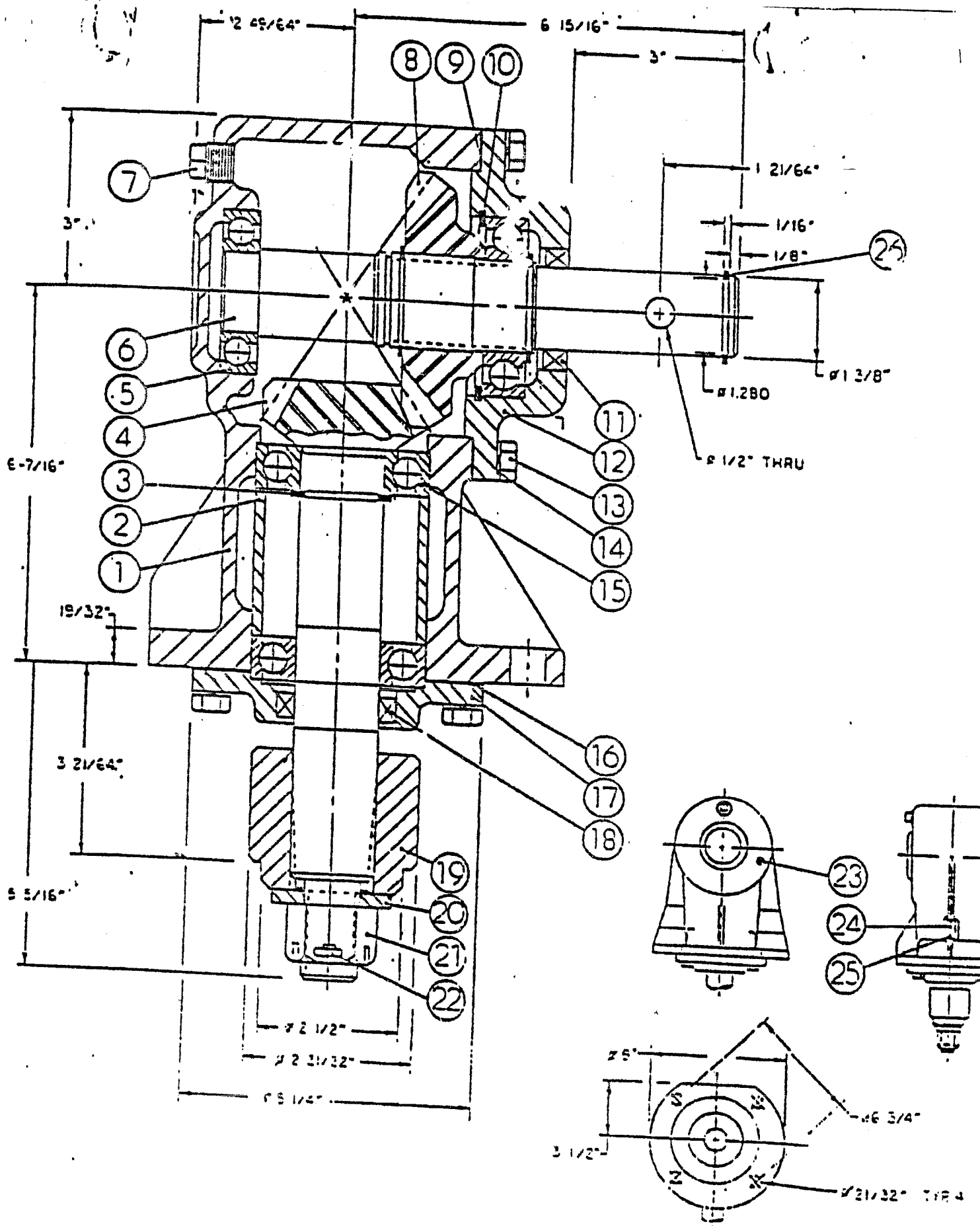

Fig. 1 Type 1 # Gearbox

GEAR BOX

No.	Part No.	Description	Quantity
1	010001CX	Housing	1
2	140000CX	1/2" Sq. HD Pipe Plug	1
3	140001CX	1/8" Sq. HD. Pipe Plug	1
4	030002CX	Output Pinion	1
5		Ball Bearing 208	3
6	200000CX	Retaining Ring	3
7	090000CX	Spacer	1
8	060003CX	Output Seal	1
9	070001CX	Output Gasket	1
10	020003CX	Output Cap	1
11		Lock Washer	10
12		Cap Screw M10 x 30	10
13	210000CX	Blade Hub	1
14	130001CX	Flat Washer	1
15	120000CX	Hex Nut	1
16	100001CX	Cotter Pin 5 x 45	1
17	050006CX	Ball Bearing 207	1
18	040040CX	Input Shaft	1
19	030003CX	Input Gear	1
20	200001CX	Retaining Ring 80	1
21	070002CX	Input Gasket	1
22	020002CX	Input Cap	1
23	060002CX	Input Seal	1
24	200040CX	Retaining Ring	1



OMNI GEAR BOX PARTS LIST

40 hp GEAR BOX BREAKDOWN

Reference No.	Part #	Description	Number Required
1	010001	Housing	1
2	090000	Spacer	2
3	200000	Retaining Ring	3
4	030002	Pinion 15T	1
5	050006	Ball Bearing 207K	1
6	040040	Input Shaft	1
7	140000	Pipe Plug	1
8	030003	Gear 22T	1
9	070002	Gasket	1
10	200001	Retaining Ring	1
11	060060	Seal	1
12	020002	Cap	1
13	110000	Cap Screw	10
14	130002	Lockwasher	10
15	060007	Ball Bearing 208K	3
16	070001	Gasket	1
17	020003	Cap	1
18	060061	Seal	1
19	210000	Blade Hub	1
20 & 21	120050	Hex Nut & Flat Washer	1
22	100001	Cotton Pin	1
23	140001	Pipe Plug	1
24	190000	L D Tag	1
25	240001	Rivet	2
26	200010	Retaining Ring	1

(COVER) GEAR BOXES -

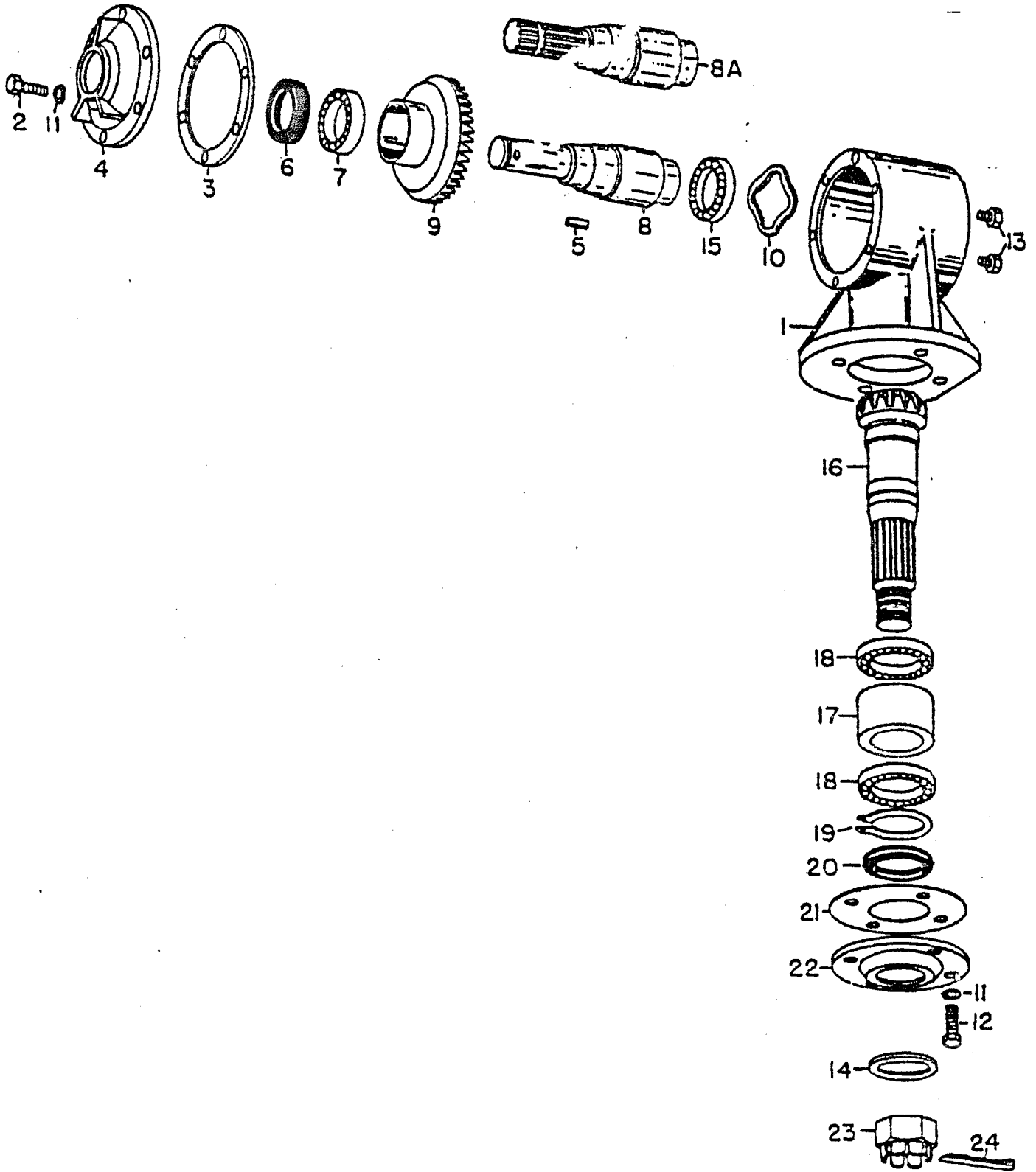

COMER GEAR BOXES

Reference Number	Part Number	Description	Number Requested
		Gear box assembly – 42 inch	1
		Gear box assembly – 48, 60 & 72 inch	1
		Gear box assembly – Optional on 60 & 72 inch Rotary Cutter with Slip Clutch	1
1	0.119.0302	Housing order gear box assembly	1
2	*	Capscrew – M1001.25 x 30	6
3	0.119.7200	Gasket – Front cover	1
4	0.119.1300	Cover – Front Cap	1
5	8.4.1.00495	Key – 12 x 8 x 35	1
6	8.7.3.00028	Oil seal – front cover 35 x 52 x 7	1
7	8.0.1.00870	Bearing – Ball	1
8	0.119.2000	Shaft – Input – Rotary Cutters without Slip Clutch – All Models	1
9	0.119.5000	Gear – Input shaft – 40, 60, & 72 inch	1
10	8.5.6.00519	Ring – Take Up – 61 x 51 x .05	1
11	*	Lockwasher – external tooth – M10	10
12	*	Capscrew – M10 – 1.25 x 22	4
13	8.6.5.00203	Oil Plug	2
14	*	Washer – M24	1
15	8.0.1.00010	Bearing Ball	1
16	0.119.6201	Pinion – Output shaft – 48, 60, & 72 inch	1
17	0.119.710	Spacer – Output Shaft Bearings	1
18	8.0.1.00871	Bearing Ball	2
19	8.5.1.00029	Ring – Retaining – External – M40	1
20	8.7.1.00517	Oil Seal – Bottom Cover	1
21	0.119.7201	Gasket – Bottom Cover	1
22	0.119.1301	Cover – Bottom Cap	1
23	8.2.2.00515	Nut – Castle – M24 – 2.0	1
24	*	Cotter Pin – M5x50	1

***Common Hardware – Purchase Locally
(Grade 5 Where Applicable)**

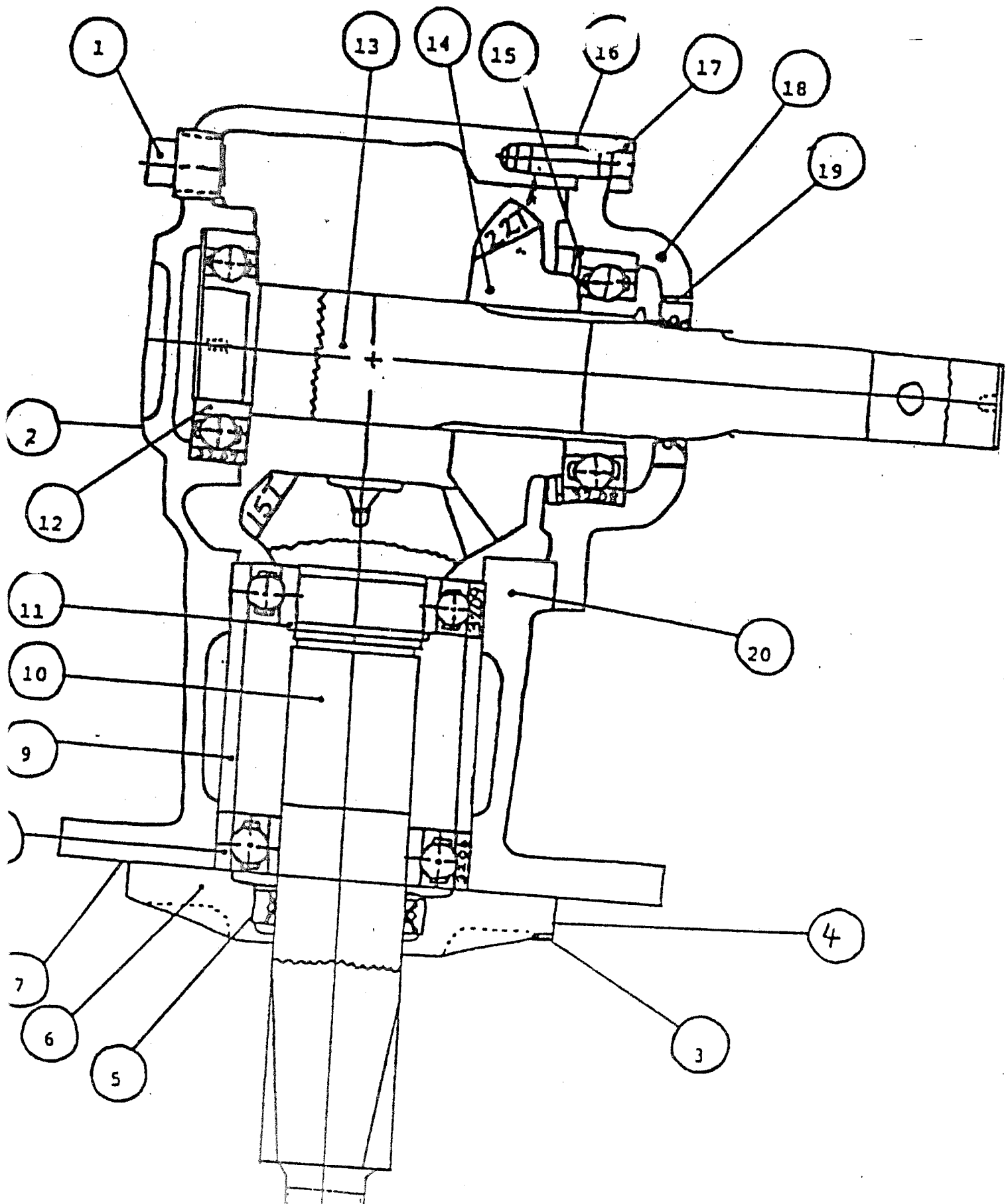

Borg – Warner Gear Boxes 40 hp Gear Box Breakdown

Reference Number	Part Number	Description	Number Requested
1	03-04-101-12	Pipe Plug (Fill)($\frac{1}{2}$ - 14)	1
2	03-04-101-09	Pipe Plug (Check) ($\frac{1}{8}$ - 27)	1
3	03-02-103-05	Capscrew $\frac{3}{8}$ " x 1"	6
4	03-03-102-08	Lockwasher	10
5	05-04-105-33	Bottom Oil Seal	1
6	10-30-104-11	Bottom Cap, Bearing Retainer	1
7	WA-48-12	Gasket	1
8	04-03-104-03	Bearing (3208)	3
9	10-30-107-01	Spacer	1
10	WA50-5E	Output Pinion	1
11	03-05-101-09	Retaining Ring	1
12	04-03-104-02	Bearing (3027)	1
13	10-30-103-02	Input Shaft	1
14	10-30-106-11	Input Gear	1
15	10-40-143-01	Retainer Ring	3
16	WA50-10-10A	Shim (.004)	As req
17	03-02-103-04	Capscrew $\frac{3}{8}$ " x 1 $\frac{1}{4}$ "	4
18	10-30-105-11	Side Housing (Front Cap)	1
19	05-02-106-06	Oil Seal (Top) (N450135)	1
20	10-30-102-11	Housing	1

BONDIOLI PARTS APPLICATION TO PTO SHAFTS ON BIG BEE ROTARY CUTTERS

(AGRI SERIES)

REF.#	PART NO.	DESCRIPTION	APPLICATION				
			AG 12,AG 4,	AG 5,	AG 66,	AG 72.	
1	63481	IMPLEMENT YOKE	*	*	*	*	*
2	4.41	BEARING & CRUSH KIT	*	*	*	*	*
3	4.11	CIRCLIP	*	*	*	*	*
4	1.49	GREASE ZERK	*	*	*	*	*
5	204.61-465	YOKE & OUTER TUBE	*	*			
5	204.61-590	YOKE & OUTER TUBE			*		
5	204.61-740	YOKE & OUTER TUBE				*	*
6	3.17.02	RING FOR OUTER TUBE	*	*	*	*	*
7	3.18.02	RING FOR INNER TUBE	*	*	*	*	*
8	204.62.490	YOKE & INNER TUBE	*	*			
8	204.62.615	YOKE & INNER TUBE			*		*
8	204.62.765	YOKE & INNER TUBE				*	*
9	4.05.07	QUICK RELEASE YOKE	*	*	*	*	*
10	1.08.25.01	RELEASE YOKE PIN	*	*	*	*	*
11	4.65.02	LOCK FOR OUTER SHIELD	*	*	*	*	*
12	4.66.02	LOCK FOR INNER SHIELD	*	*	*	*	*
13	M12664.70	UNASSEMBLED COMPLETE IMP. HALF	*	*			
13	M12666.70	UNASSEMBLED COMPLETE IMP. HALF			*		*
13	M12663.80	UNASSEMBLED COMPLETE IMP. HALF				*	*
14	M12664.71	UNASSEMBLED COMPLETE TRAC. HALF	*	*			
14	M12666.71	UNASSEMBLED COMPLETE TRAC. HALF			*		*
4	M12663.81	UNASSEMBLED COMPLETE TRAC. HALF				*	*
15	3.75.420	OUTER HALF SHIELD	*	*			
15	3.75.545	OUTER HALF SHIELD			*		
15	3.75.695	OUTER HALF SHIELD				*	*
16	3.74.420	INNER HALF SHIELD	*	*			
16	3.74.545	INNER HALF SHIELD			*		
16	3.74.695	INNER HALF SHIELD				*	*
17	M12664Z	COMPLETE SHIELD W/ LOCKS & RINGS	*	*			
17	M12666Z	COMPLETE SHIELD W/ LOCKS & RINGS			*		
17	M12663Z	COMPLETE SHIELD W/ LOCKS & RINGS				*	*
18	M12664	COMPLETE PTO SHAFT 31 inches SERIES #4	*	*			

18	M12666N	Complete PTO Shaft 37"							
		Series #4				*			
18	M12663N/A	Complete PTO Shaft 43"						*	*
		Series #4						*	*
19		Stay Chain	*	*	*	*	*	*	*

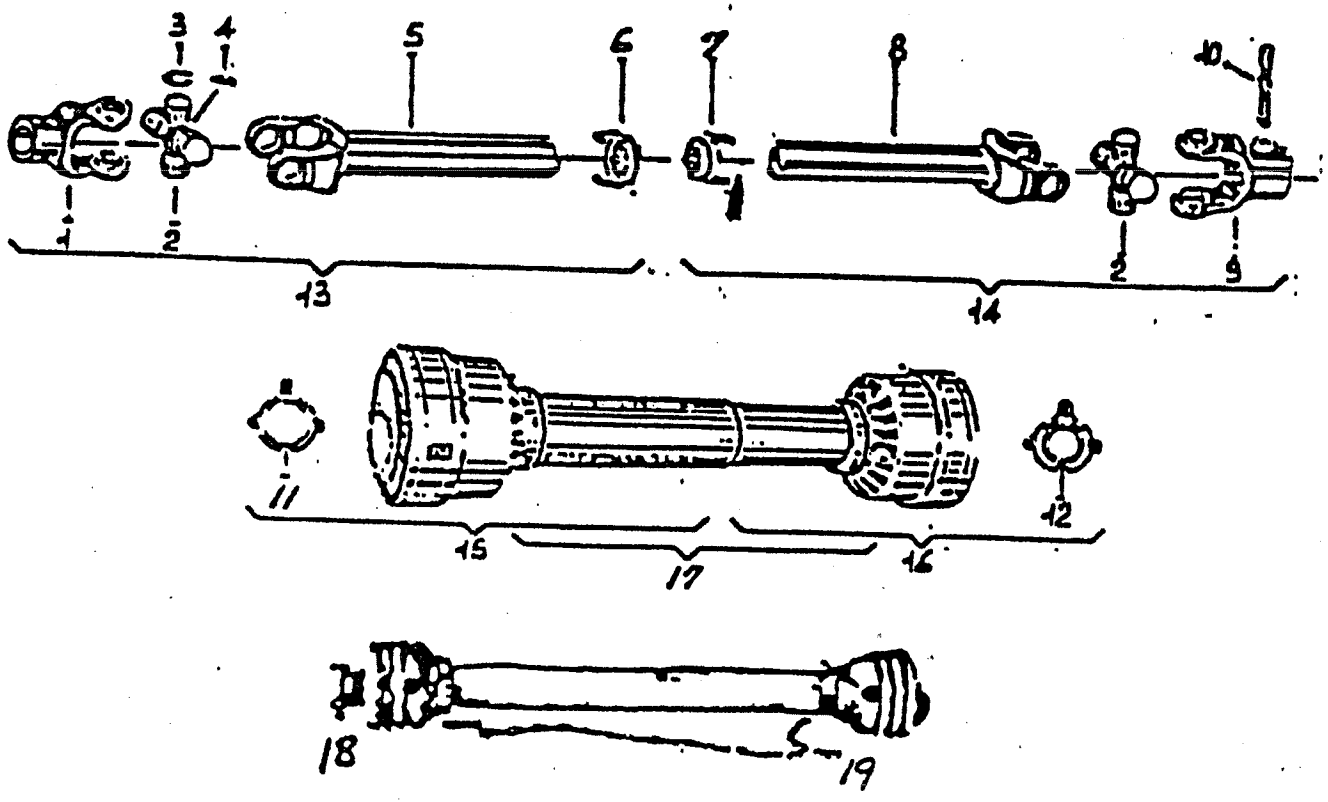

IT IS UP TO YOU

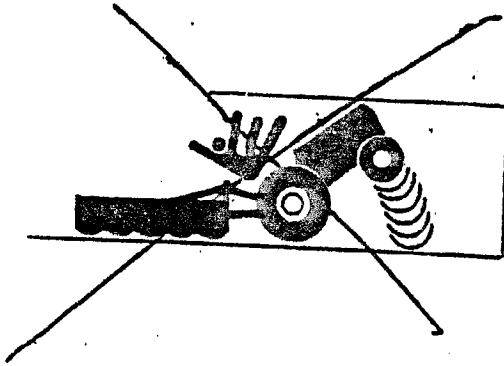

*
* REMEMBER: SAFETY FIRST *
*

BETTER TO BE "SAFE" THAN "SORRY"

Don't find out the hard way that careless actions can make you, your family, your friends, or an innocent by-stander the victim of an accident. Safety is an everyday need. Outfit yourself with a complete safety program.

Read Your Operator's Manual Thoroughly: Know how to operate your machine properly and safely. Always take the necessary safety precautions.



THINK BEFORE YOU ACT

Sold By:

GENERAL MAINTENANCE

1. Tractor and Rotary Cutter must be "shut off" (disengaged from any power) before any acts of maintenance are performed.
2. Check oil level in gear box periodically. Keep level up to check plug. Use SAE 90 or SAE 140 transmission oil. Use caution not to over fill.
3. Lubricate universal joint on PTO shaft every few hours of use. Keep PTO shaft free of dirt and foreign materials so that it will telescope freely to avoid damage to your tractor or rotary cutter.
4. Lubricate tail wheel.
5. Keep blades sharp. When replacing worn blades, be sure to replace in pairs to maintain rotary balance.
6. Keep all bolts tightened properly.

WARRANTY

We warrant each new Big Bee Rotary Cutter against defect in material or workmanship for a period of 90 days or a reasonable period time dependent upon the type of use of the machine.

In the event that it is necessary to replace or repair any part(s) during the warranty period go to your dealer with the defective part(s) and he will assist you in securing the needed replacement or return the defective part(s) to DHE Warranty Division, P.O. Box 140 - Golden Road, Red Bay, Alabama 35582.

Neither manufacturer or the dealer shall be held responsible for loss of use of the machine, loss of time, inconvenience, commercial loss, or consequential damages.

In order for your Big Bee Rotary Cutter to be covered by our warranty policy, the equipment registration form on the back cover must be completed and returned within 10 days after the purchase date.

The warranty policy is not effective unless the equipment registration is recorded in our office.

OWNER REGISTRATION

OWNER'S NAME: _____

STREET ADDRESS: _____

CITY: _____ COUNTY: _____

STATE: _____ ZIP: _____

PURCHASED FROM: _____

STREET ADDRESS: _____

CITY: _____ COUNTY: _____

STATE: _____ ZIP: _____

DATE PURCHASED:

DATE: _____

OWNER'S SIGNATURE: _____

MODEL: _____

EQUIPMENT NAME: _____

SIZE: _____
