

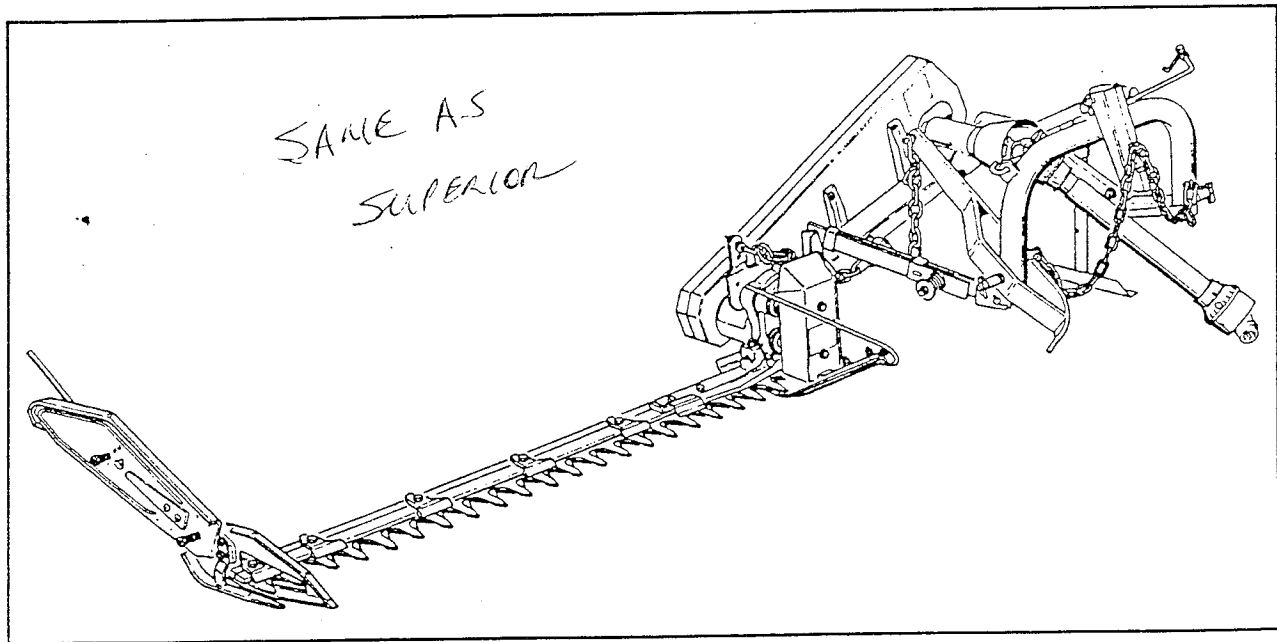

AGRICULTURAL MACHINERY

**sitrex**®  
s.r.l.

**ASSEMBLY,  
USE AND MAINTENANCE  
SPARE PARTS LIST**



**SB/165 – SB/180 – SB/210**

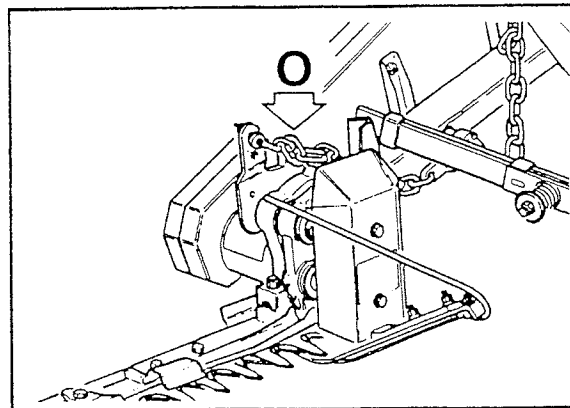
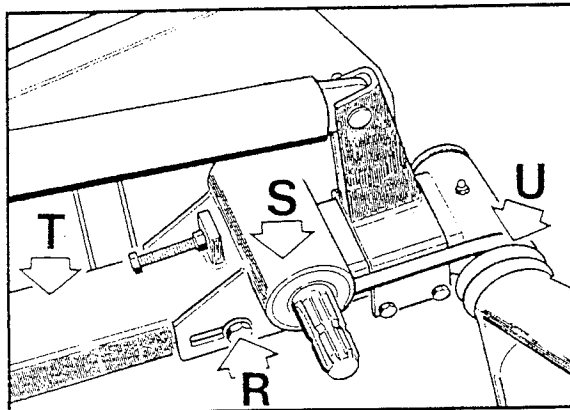
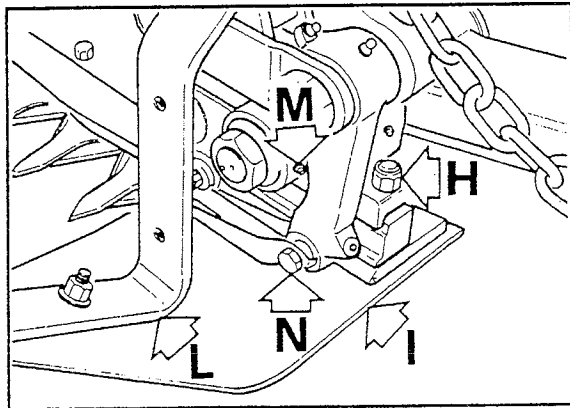
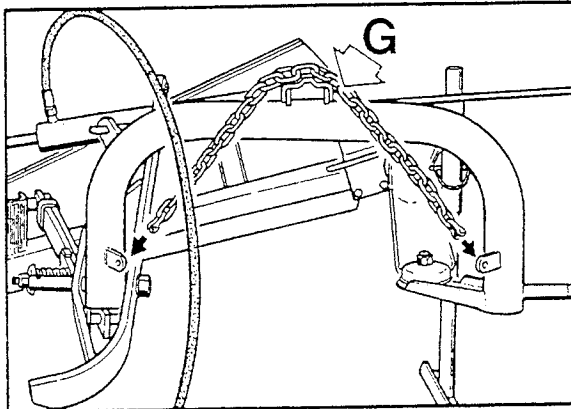
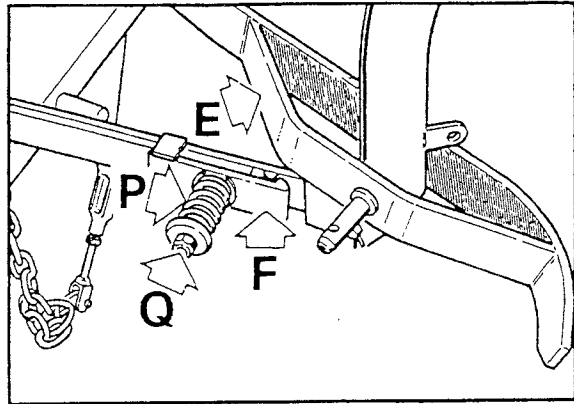
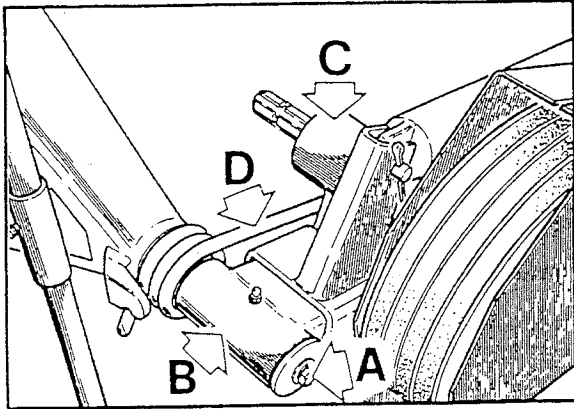

**ASSEMBLY INSTRUCTIONS**

INSERT THE PIN OF THE CENTRAL SUPPORT (Rif.A) INTO THE ARM (Rif.B), RESTING THE DRIVING SUPPORT (Rif.C) ON THE LONG PART OF THE SPRING (Rif.D) AFTER HAVING PLACED THE SHORT PART OF THE LATTER IN THE APPROPRIATE STOP.

MOUNT THE LIFTING LEVER (Rif.E) AND CONNECT THE FRAME TO THE BRACKET BY MEANS OF THE UNHOOKINGKIT (Rif.F). THEN CONNECT THE CHAIN (Rif.G) TO THE FRAME MAKING USE OF THE APPROPRIATE FASTENERS.

MOUNT THE BAR CLOSING THE BOLTS (Rif. H) IN THE FITTING HOLES OF THE MAIN BODY, THEN CONNECT THE SHOE (Rif. I) TO THE MAIN BODY WITH BRACKET (Rif. I). CONNECT THE BLADES TO THE LEVERS (Rif. N).

**USE AND MAINTENANCE**

ON COMPLETION OF ASSEMBLY, THE FOLLOWING OPERATIONS SHOULD BE CARRIED OUT TO ENSURE THAT THE MOWER WORKS PERFECTLY.

A) WORK POSITION: POSITION THE MACHINE ON THE THREE POINTS OF THE TRACTOR AND LIFT THE SUPPORTING FOOT-WORK ON TUE 3RD POINT TO OBTAIN THE CUTTING HEIGHT REQUIRED AND ON THE STABILIZING CHAINS TO OBTAIN THE CORRECT GAUGE. REGULATE THE LIFT STROKE IN SUCH A WAY AS TO PREVENT THE CARDAN SHAFT WORKING AT ELEVATED ANGULATIONS (MAXIMUM OF 25° IS ADVACED), AND ALWAYS MAKE SURE THAT THE POWER TAKE-OFF IS DISCONNECTED BEFORE WORKING THE LIFT.

B) CHAIN REGULATION: ADJUST THE CHAIN LENGHT (Rif.G) TO OBTAIN THE EXACT FRAME POSITION, ENSURING THAT THE RELEASE DEVICE ROTATES FREELY WITHOUT INTERFERENCE IN ANY POINT WHEN THE LIFT IS WORKED, AND THE LENGHT OF THE DOUBLETREE CHAIN (Rif.0) TO OBTAIN AN OPTIMUM BAR LIFT.

C) SAFETY RELEASE: THE MACHINES ARE PROVIDED WITH A SAFETY RELEASE, SET AT DEPARTURE, WHICH PERMITS THE BAR TO ROTATE BACKWARDS IN CASE OF IMPACT. SHOULD THE RELEASE FAIL TO WORK FOR CAUSES RELATIVE TO PARTICULAR GROUND, THE PRESSURE OF SPRING (Rif.P) SHOULD BE INCREASED OR DECREASED BY MEANS OF THE SELF-LOCKING NUT (Rif.Q).

D) BELT TENSION: THE BELT TENSION SHOULD BE CHECKED, AT LEAST DURING THE FIRST 24 HOURS OF WORK. TO INCREASE THE TENSION LOOSEN THE TWO BOLTS (Rif.R) AND SUBSEQUENTLY TIGHTEN THE APPROPRIATE SCREW, CAUSING THE SUPPORT (Rif.5) TO SLIDE ON THE BRACKET (Rif.T), AFTER WHICH TIGHTEN THE LOCK

TABLE 01 SB

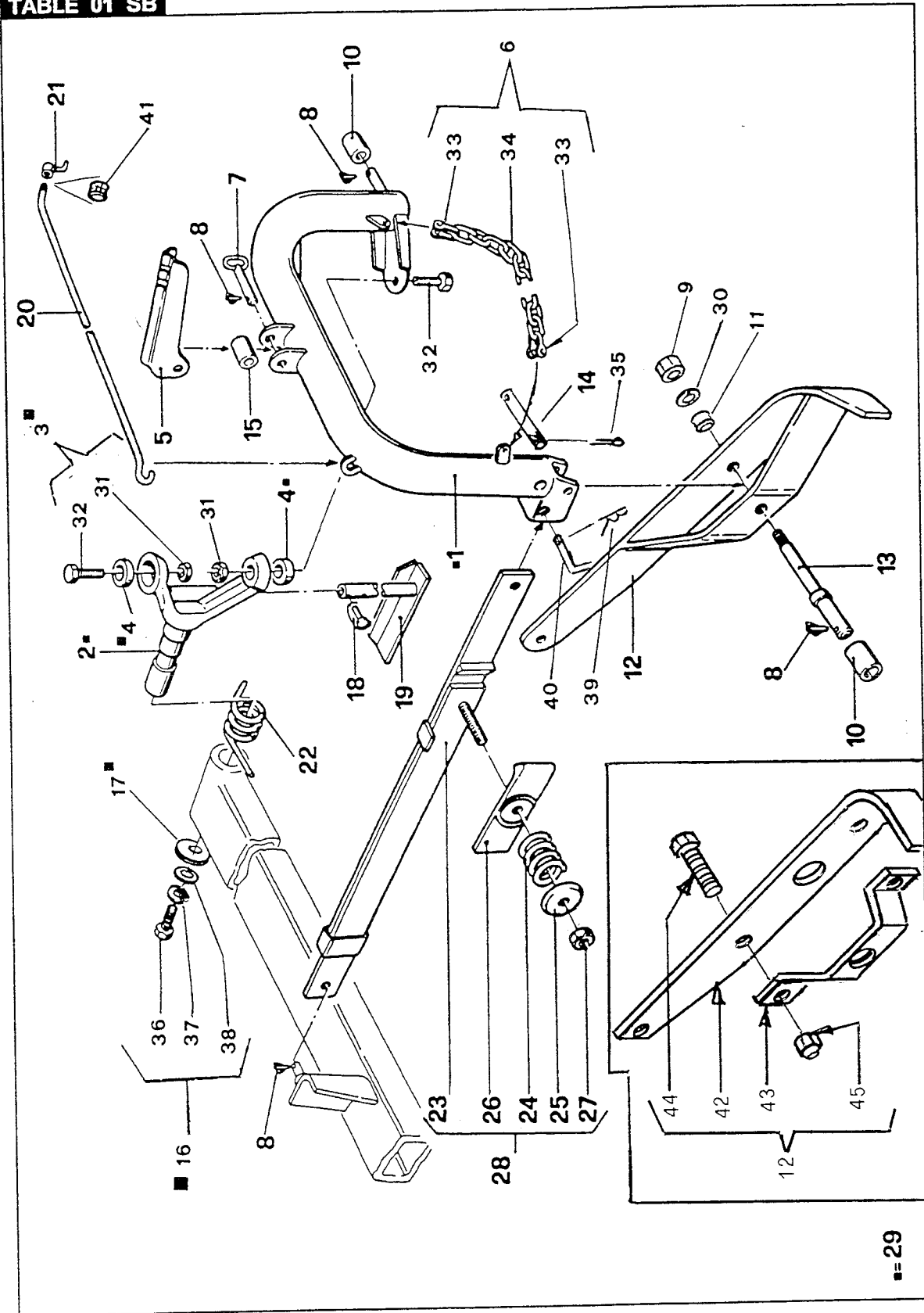

■=29

TAB. 01 SB			
ITEM	PART.NO	DESCRIPTION	NOTE
1	100.368	FRAME	
2	100.369	SUPPORT	
3	610.605	BOLT, COMPLETE	
4	100.370	SPACER	
5	100.371	GEAR RACK	
6	100.372	CHAIN, COMPLETE	
7	100.373	PIN	
8	610.606	PIN	
9	600.244	NUT M24x2 DIN 934 CLASS 8	
10	100.374	REDUCER INSERT	
11	100.375	SPACER	
12	100.376	LEVER	
13	100.377	PIN	
14	100.378	PIN	
15	100.379	REDUCER INSERT	
16	610.608	BOLT, COMPLETE	
17	100.380	WASHER	
18	600.842	PIN	
19	100.382	SUPPORT	
20	100.383	TIE ROD	
21	100.518	HANDLE	
22	100.384	SPRING	
23	100.385	ICE SLED	
24	100.387	SPRING	
25	100.388	WASHER	
26	100.389	PLATE	
27	600.197	NUT M16 DIN 982 CLASS 6	
28	100.390	ICE SLED	
29	100.392	FRAME	
30	610.686	WASHER D. 28 UNI 1751A	
31	610.685	SPECIAL NUT	
32	610.684	SCREW M18x1.5x65 DIN 960 CLASS 8.8	
33	610.687	THIMBLE 3/8"	
34	100.516	CHAIN	
35	600.038	SPLIT PIN 6x35 DIN 94	
36	600.616	SCREW M12x35 DIN 933 CLASS 8.8 ZN	
37	600.018	WASHER D. 13 UNI 1751A	
38	600.089	WASHER D. 13 DIN 125A	
39	600.015	PIN	
40	100.517	PIN	
41	600.084	NUT M16 UNI 5587 CLASS 8	
42	100.526	LEVER	
43	100.527	SUPPORT	
44	600.280	SCREW M14 x 45 DIN 933 CLASS 8.8	
45	600.626	NUT M14 DIN 982 CLASS 6	

TABLE 06 SB

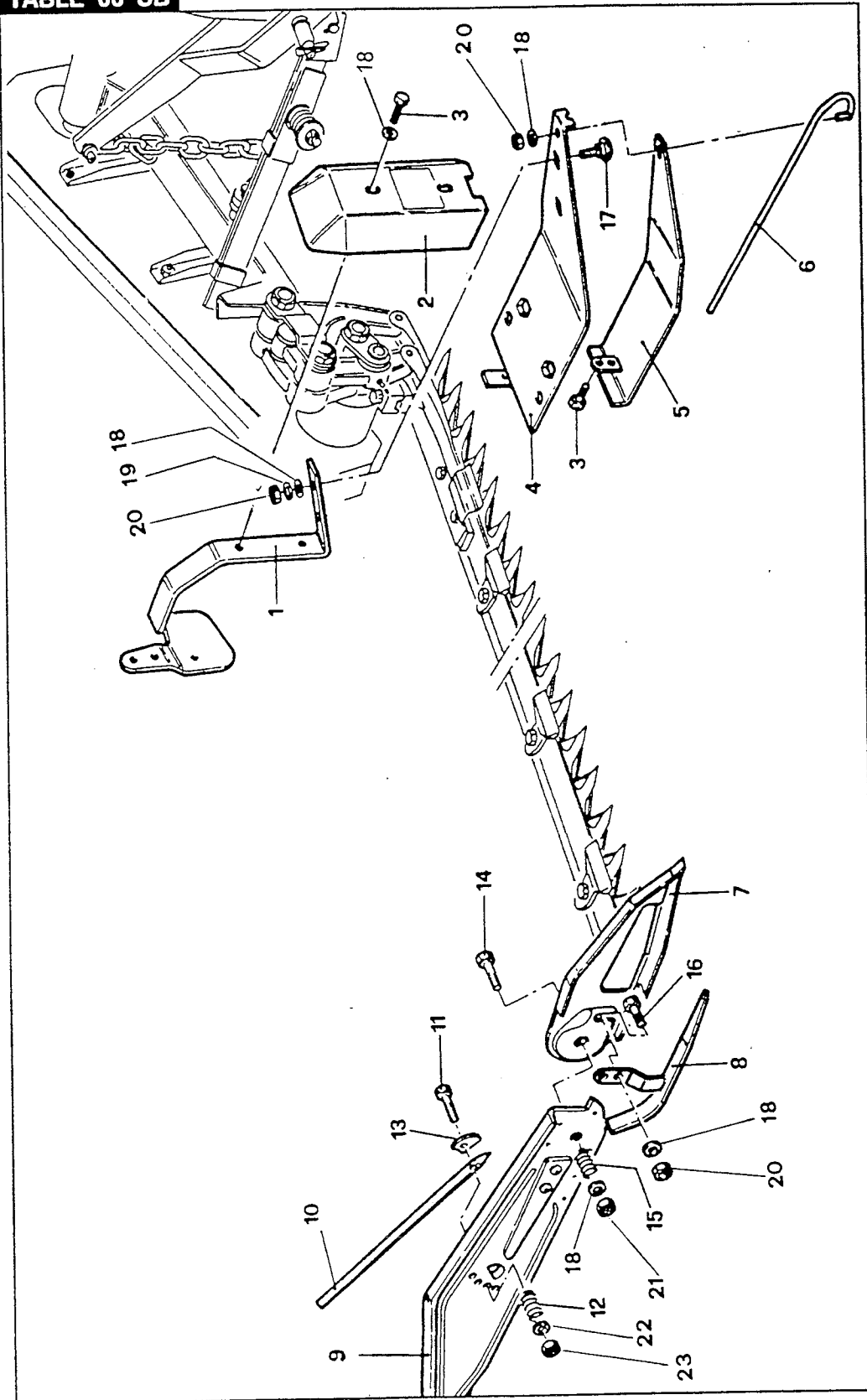

TAB. 06 SB			
ITEM	PART.NO	DESCRIPTION	NOTE
1	100.435	SUPPORT	
2	100.436	CASING	
3	600.770	SCREW M12x20 DIN 933 CLASS 8.8	
4	100.437	SHOE	
5	100.438	SOLE	
6	100.439	ROD	
7	100.440	SHOE	
8	100.441	SOLE	
9	100.443	OUTER SWATH BOARD	
10	100.445	SWATH STICK	
11	610.641	SCREW M8x70 DIN 603 CLASS 6.8	
12	100.447	SPRING	
13	100.448	FASTENINGS	
14	600.210	SCREW M12x70 DIN 931 CLASS 8.8	
15	100.449	SPRING	
16	610.643	SPECIAL SCREW	
17	610.644	SPECIAL SCREW	
18	600.089	WASHER D. 13 DIN 125A	
19	600.018	WASHER D. 13 UNI 1751	
20	600.624	NUT M12 UNI 5587 CLASS 8	
21	600.077	NUT M12 DIN 980 CLASS 8	
22	600.115	WASHER	
23	610.693	NUT M8 DIN 982	

TABLE 08 SB

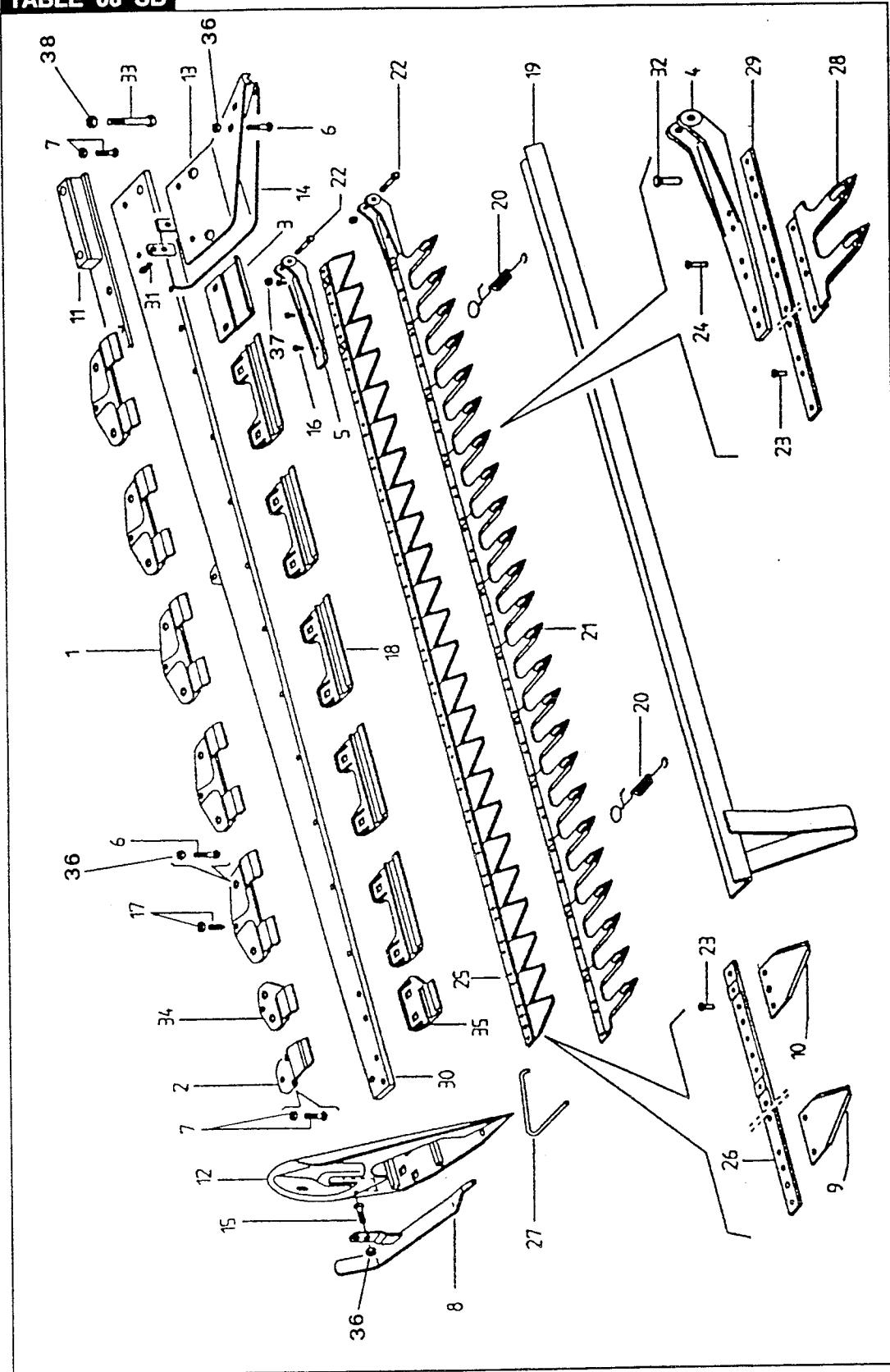



TAB. 08 SB			
ITEM	PART.NO	DESCRIPTION	NOTE
1	100.459	BLADE HOLDER	
2	100.460	BLADE HOLDER	
3	100.461	GUIDE	
4	100.462	BLADE HEAD	
5	100.463	BLADE HEAD	
6	610.644	SPECIAL SCREW	
7	610.656	SPECIAL BOLT	
8	100.441	SOLE	
9	100.464	SECTION	
10	100.466	SECTION 3 HOLES	302452
11	100.468	STIFFENER	
12	100.469	OUTER SHOE	
13	100.437	INNER SHOE	
14	100.438	INNER SOLE	
15	610.643	SPECIAL SCREW	
16	610.657	SPECIAL BOLT	
17	610.658	SPECIAL SCREW	
18	100.470	GUIDE	
19	100.472	LINER	SB 165
19	100.473	LINER	SB 180
19	100.474	LINER	SB 210 η'
20	100.475	SPRING	
21	100.477	BLADE 165	
21	100.478	BLADE 180	
21	100.479	BLADE 210	302450
22	610.659	SPECIAL SCREW	
23	100.480	RIVET 5X13	302453
24	100.481	RIVET 5X22	302454
25	100.483	BLADE 165	
25	100.484	BLADE 180	
25	100.485	BLADE 210 η'	302451
26	100.487	DRILLER BAR 165	
26	100.488	DRILLER BAR 180	
26	100.489	DRILLER BAR 210 η'	
27	100.490	HAULAGE HOOK	
28	100.491	KNIFE TOOTH	302456
29	100.493	DRILLER BAR 165	
29	100.494	DRILLER BAR 180	
29	100.495	DRILLER BAR 210 η'	
30	100.497	CUTTER BAR 165	
30	100.498	CUTTER BAR 180	
30	100.499	CUTTER BAR 210 η'	
31	600.770	SCREW M12x20 DIN 933 CLASS 8.8	
32	100.500	RIVET 7X24	
33	610.628	SCREW M16x1.5x110 DIN 960 CLASS 8	
34	100.501	BLADE HOLDER	
35	100.502	GUIDE	
36	600.624	NUT M12 UNI 5587 CLASS 8	
37	600.077	NUT M12 DIN 980 CLASS 8	
38	610.691	NUT M16x1.5 DIN 982 CLASS 8	

TABLE 07 SB

